

SPV SPINTEC | HYDRO CHUCKS

The widest assortment on the market. For all applications.



DRILLING

MILLING

REAMING

THREAD MILLING

SPV SPINTEC:s Hydro chucks gives you:

- Possibility to work with closer tolerances.
- Improved surface finish.
- Up to 50% longer tool lifetime compared to other conventional tool holder systems.
- High clamping force. Example: 320 Nm on a standard hydro chuck Ø20 mm.
- Runout accuracy better than 0,003 mm.
- Faster and simpler tool changes. No extra equipment needed.
- Balanced for 10.000 RPM (G6,3) - can be supplied fine balanced.

Apart from our standard assortment you can decide what your chuck should look like.

SPV SPINTEC AB

Fabriksgatan 13 , SE-633 46 Eskilstuna , SWEDEN

Tel: +46 - 16 - 15 30 30 | Fax: +46 - 16 - 51 34 64

E-mail: info@spvspintec.se | Website: www.spvspintec.se

 **SPV SPINTEC**[®]
www.spvspintec.se

Maximum stability with SPV Spintec's unique multi-angular milling membrane (+)

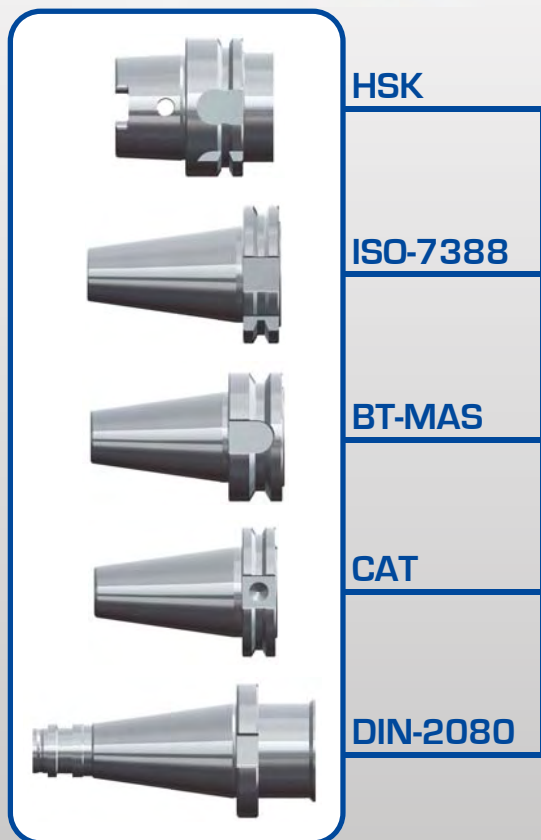

Extra short chuck HCK+ for better milling performance. Milling membrane (+) as standard. (Example: 600Nm with Ø20) HSK-A63, ISO-40 & BT-40 available.



HCF
HCF+ Short standard chuck
Can be provided with milling membrane (+)



HCFL
HCFL+ Extra long standard chuck
Can be provided with milling membrane (+)

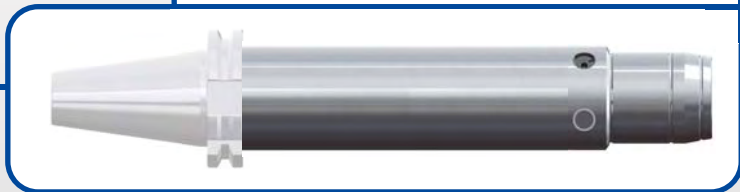

HCPK+ Tapered long chuck with milling membrane (+) as standard



HCP+ Pen chuck in two different lengths with milling membrane (+) as standard

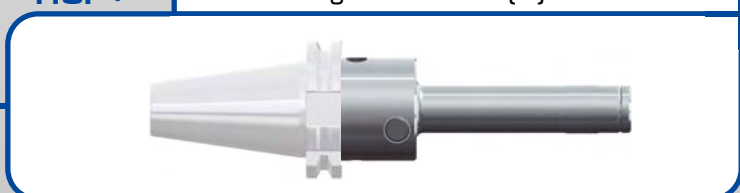

HCPS Extra slim pen chuck in two different lengths with milling membrane (+) as standard



All chucks can be delivered with any machine taper and as extended models up to 515 mm gauge length according to your needs.
Time of delivery: 2 weeks

We also manufacture custom designed Hydro chucks for special purposes.